

# 966K

Wheel Loader



## Engine

Engine Model	Cat® C9.3 ACERT™	
Max. Net Power (1,800 rpm) – ISO 9249	199 kW	267 hp
Max. Net Power (1,800 rpm) – ISO 9249 (metric)		271 hp
Max. Net Power (1,800 rpm) – SAE J1349	199 kW	267 hp

## Buckets

Bucket Capacities	2.5 m <sup>3</sup> -9.2 m <sup>3</sup>	3.25 yd <sup>3</sup> -12.0 yd <sup>3</sup>
-------------------	--	--

## Weights

Operating Weight	24 189 kg	53,311 lb
------------------	-----------	-----------

• For 4.2 m<sup>3</sup> (5.5 yd<sup>3</sup>) general purpose buckets with bolt-on cutting edges.

## 966K Features

### Performance Series Buckets

*With standard Performance Series Buckets, operators benefit from reduced dig times and better material retention; ultimately translating into significant productivity and fuel efficiency improvements.*

### Load Sensing Hydraulics

*Load sensing hydraulics produce flow and pressure for the implement system upon demand and only in amounts necessary to perform the needed work functions, enhancing machine productivity and fuel efficiency.*

### Operator Environment

*The new four post ROPS cab provides enhanced comfort, visibility, and productivity resulting in a more efficient operator. New features include an ergonomic electro-hydraulic (EH) joystick steering system with position control and force feedback (speed sensitive), automatic climate control, viscous mounts to reduce noise and vibration levels, post mounted membrane switches, and a convex windshield giving the operator a panoramic view.*

### Cat® C9.3 ACERT™ Engine

*The innovative Cat C9.3 ACERT engine is optimized for maximum fuel efficiency and increased power density while meeting all Tier 4 Interim/Stage IIIB emission standards.*

### Powershift Transmission

*The K Series™ transmissions incorporate a new shifting strategy that delivers smoother shifts, faster acceleration, and increased travel speed when climbing a grade.*

### Fuel Efficiency

*The 966K wheel loader has been integrated as a system; from the linkage and work tool carrying the payload, to the engine, transmission and torque converter moving the machine, the system has been optimized to achieve the lowest cost per ton.*

### Contents

Reliability .....	3
Durability .....	4
Productivity .....	5
Versatility .....	6
Operator Environment .....	8
Serviceability .....	10
Sustainability .....	11
Customer Support .....	11
Owning Costs .....	12
Operating Costs .....	13
Wheel Loader Specifications .....	14
Standard and Optional Equipment .....	28



**The Cat® 966K was designed to improve operator comfort, performance, and productivity, all while meeting Tier 4 Interim/Stage IIIB emission standards. The Performance Series Buckets enhance visibility and decrease cycle times. The unmatched, revolutionary world-class cab creates a comfortable, efficient, safe, and productive operator environment. The innovative Cat C9.3 ACERT™ engine is optimized for maximum fuel efficiency and increased power density while meeting all Tier 4 Interim/Stage IIIB emission standards. The reliability, durability, and versatility of the 966K result in a machine that is better built to meet your needs. All day. Every day.**

# Reliability

Tested and Proven. Ready to Work.

## Structures

The K Series™ features many of the components designed and proven reliable over generations of product design.

## Strata Precleaner

The system removes 93% of the dust particles before the air has reached the primary engine air filter. As air enters the precleaner, stationary vanes cause the incoming air to spin. The resulting centrifugal force spins dust and dirt to the outer walls where they are ejected out into the exhaust stream, while the clean air flows down the center of the tube and continues into the primary air filter. The primary benefit is extended filter life.

## Cold Start/High Altitude Package

A new optional cold start package includes a fan pump bypass, transmission pump bypass, additional battery capacity, and an engine heater plug/cord. The bypass systems reduce the parasitic load on the engine, while the additional battery capacity increases the cold cranking revolutions during startup. With the new optional cold start package available on K Series, starting capability has been dramatically improved in cold weather conditions. The system also improves starting capability at high altitudes.

## Monitoring Programs

Monitoring product health is key to maintaining reliability of any equipment. Many programs offered by Caterpillar make the tracking of the customer's machine health quick and easy. These programs include Product Link, VisionLink™, and S·O·S<sup>SM</sup> Services.

## Renowned Cat Dealer Support

From helping you choose the right machine to knowledgeable support, Cat dealers provide the best when it comes to sales and service. Manage costs with preventive maintenance programs like Scheduled Oil Sampling (S·O·S<sup>SM</sup>) analysis or elaborate Customer Support Agreements. Stay productive with best-in-class parts availability. Cat dealers can even help you with operator training to help boost your profits. And when it's time for machine rebuild, your Cat dealer can help you save even more with Genuine Cat Reman parts. Receive the same warranty and reliability as new products at cost savings of 40 to 70 percent for power train and hydraulic components.



# Durability

Better Built to Meet Your Needs



## Frames

The robotically welded two-piece structural frame design provides a rugged and reliable foundation for the machine that improves stability, performance, and serviceability. A robust articulating hitch system joins the front and rear frames improving durability. Enhanced lines routings across the hitch joint streamline the manufacturing process and improve reliability and durability.

## Engine

The new Cat C9.3 ACERT engine was designed to optimize power density. It uses a combination of technologies to reduce regulated emissions while ensuring high performance and excellent fuel efficiency. An upgraded ADEM™ 4 electronic control module manages the combustion process and a new high-pressure common rail fuel system allows precise injection timing for a clean, efficient fuel burn. The rugged Cat Clean Emissions Module is securely rubber mounted on its own platform above the engine and contains a Diesel Oxidation Catalyst, Diesel Particulate Filter and Cat Regeneration System. Regeneration, the process by which soot is removed from the Diesel Particulate Filter, is completely automatic and does not interrupt the machine's work cycle.

## Emissions

The 966K features a Cat C9.3 ACERT engine and a Cat Clean Emissions Module to deliver the performance and efficiency that customers demand, while meeting Tier 4 Interim/Stage IIIB emission standards. The six-cylinder electronic engine is turbocharged and aftercooled. ACERT™ Technology is a combination of building blocks that includes electronics, fuel systems, air management systems and aftertreatment components. The system is optimized based on engine size, the type of application and the geographic location in which it will work. The technologies are applied systematically and strategically to meet high customer expectations for productivity, fuel efficiency, reliability and service life.

## Axles

The 966K axles are designed to handle extreme applications resulting in reliable performance and extended life. The front axle is rigidly mounted to the frame in order to withstand internal torque loads and still maintain support for the wheel loader. The rear axle can oscillate to  $\pm 13$  degrees helping to ensure all four wheels stay on the ground providing stability even in the roughest terrain.





# Productivity

Move More. All Day. Every Day.

## Z-bar Linkage

The proven Z-bar linkage with Performance Series Buckets offer excellent penetration into the pile, high breakout forces, good roll back angles, and faster dig times. The results are improved tire life, superior fuel efficiency, and exceptional production capabilities; all helping to enable a sustainable solution for your business.

## Load Sensing Hydraulics

Load sensing hydraulics produce flow and pressure for the implement system upon demand and only in amounts necessary to perform the needed work functions, enhancing machine productivity and fuel efficiency. Implement controllability is improved through simultaneous implement operation and repeatable fine modulation, enabling greater operator comfort through ease of operation.

## Ride Control

Ride control provides the operator with a smoother ride over rough terrain, enabling a more comfortable ride at higher speeds. The benefit is reduced cycle times, higher productivity and better fuel efficiency while performing load and carry applications. The system works by using an accumulator to dampen the linkage motion, acting as a shock absorber.

## Torque Converter

The 966K torque converter is optimized to improve fuel efficiency and deliver more power to the ground.

## Transmission

The K series transmissions incorporate a new shifting strategy that delivers smoother shifts, faster acceleration, and better performance climbing a grade. When placing the transmission into forward gear, the machine will automatically start in second gear. With the further enhancement of a torque based 2 to 1 downshift, the downshift will only occur based on machine load. Owners and operators will fully benefit from utilizing the automatic 1-4 transmission mode, which results in lower fuel consumption and optimal machine performance.

# Versatility

## Work Tool Options to Meet Your Needs



### Work Tools for Many Job Site Requirements

An extensive range of work tools and bucket styles are available for the 966K to customize the machine for your operation. The list includes: Performance Series Buckets; Specialty Buckets (Multipurpose, Side Dump, Waste Handling, Woodchip); Pallet Forks, Log and Lumber Forks, Rakes (with or without top clamps); and Plows (angle or V-style). Each is available either with pin on or quick coupler interface.

### Performance Series Buckets: Load Easy, Fuel Efficient, Carry More

Performance Series Buckets utilize a system-based approach to balance bucket shape with the machine's linkage, weight, lift and tilt capacities. Operators benefit from reduced dig times and better material retention; ultimately translating into significant productivity and fuel efficiency improvements.

### Lower Operating Costs

Performance Series Buckets feature a longer floor that easily digs through the pile and provides excellent visibility for the operators to see when the bucket is full. Less time digging in the pile results in lower fuel consumption and improved tire life. A unique spill guard protects the cab and linkage components from material overflow.

### Higher Productivity

Performance Series Buckets achieve higher fill factors – ranging from 100% to 115% depending on the machine application and material type. The buckets feature optimized geometry with a bucket opening matched to the machine's linkage and incorporate a curved side profile to maximize material retention. The optimized design results in unsurpassed production capabilities.

### Performance Series Bucket Styles

Performance Series Buckets are available for General Purpose, Material Handling, Heavy Duty Material Handling, Rock and light material buckets.

# Fusion Quick Coupler

## Improved Machine Performance

Fusion™ is the patented wheel loader coupler system from Caterpillar. The Fusion Coupler System provides performance virtually identical to pin on – with all the flexibility of a quick coupler system. The Fusion Coupler sits back, close-in to the loader arms – minimizing offset and increasing the machine's performance.

## No Loss of Performance

Imagine lifting a hundred pound box with your arms fully extended. Now imagine lifting that same load close to your body. That's the genius of Fusion: designed to integrate the work tool and the machine by pulling the coupler and tool closer in to the loader. As a result, the center of gravity is moved inward, towards the machine. This translates to increased lifting ability when compared to machines equipped with other coupler systems.

## Unsurpassed Durability

An advanced wedging mechanism creates a tight, rattle-free fit. This patented lock up system eliminates play and wear – resulting in a long service life. Wedges pull the attachment tight to the machine in two directions – in and down. Constant hydraulic pressure on the coupler wedges compensate for wear, assuring a tight fit through the life of the coupler. Tight fit gives better tool control and increased productivity. Coupler durability is substantially increased over traditional couplers.

## Enhanced Visibility

An open coupler frame design clears sight lines from the operator's seat, making it easier than ever before to engage and disengage attachments with certainty. Offset tines and other design changes to Fusion Pallet Forks, working in conjunction with the Fusion Coupler, enhance visibility substantially at ground level and truck bed height when compared to traditional coupler and fork combinations.

## Common Interface Compatibility

The Fusion Coupler System gives Caterpillar customers one common interface – eliminating the need for many different couplers across the entire range of small and medium wheel loaders. This expanded machine compatibility not only allows one machine to use a range of work tools, but also allows one work tool to be picked up by machines of many different sizes.

The Fusion coupler interface is designed to work on 924 through 972 machines. Each machine will have its own optimal bucket and fork recommendations. However, cross-machine compatibility gives you additional flexibility and fleet options not found with any other wheel loader coupler.

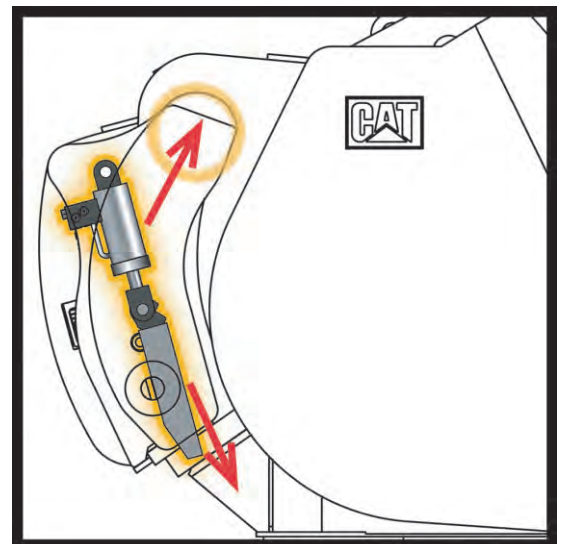
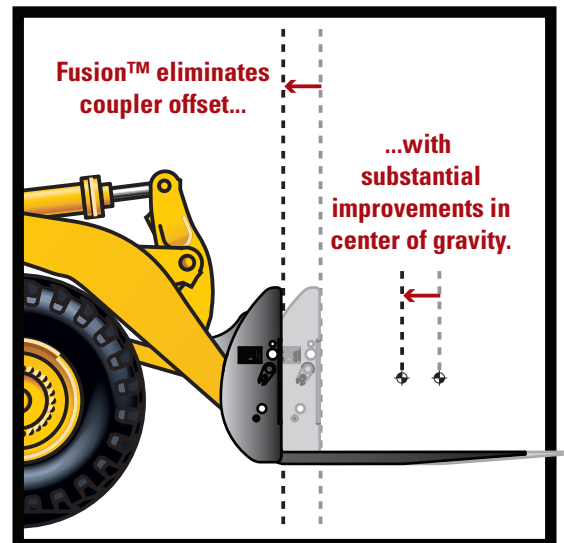

# Operator Environment

Safe. Comfortable. Efficient.



## Electro-Hydraulic (EH) Joystick Steering with Force Feedback (Speed Sensitive)

The industry leading EH joystick steering system combines operator comfort and precision control to provide a sustainable work environment for the operator. The system incorporates a force feedback motor that automatically adjusts the effort needed to tilt the ergonomic joystick based on ground speed, resulting in superior control in all applications and climates. For customers who prefer a steering wheel, an electro-hydraulic steering wheel is available as an option.

## Implement Controls (EH)

Seat mounted single axis implement control levers provide the operator with precise control of the work tool, all while moving with the seat for maximum comfort. In cab programmable kick-outs and automatic cylinder snubbing maximize operator comfort and productivity throughout their shift. Optional implement joysticks are available for 2V and 3V hydraulics.

## Seat

The Cat Optimized Seating System is 6-way adjustable to accommodate operators of all sizes. The seat has a one piece high back that supports the lumbar area of the back up through the shoulders. Both armrests are large and can be adjusted up, down, fore, and aft to enhance comfort and convenience. An optional feature for the cab seat is a heated backrest and cushion.

## Sound and Vibration

New viscous cab mounts connect the cab to the frame of the machine, decreasing noise and vibration the operator is subjected to. This contributes to a well-rested operator who remains efficient and productive. All Day. Every Day.

## Information Display

The central display panel has a large text box, five analog-like gauges, and LED warning indicators. The large text box provides in-language information about machine operation, feature activation and system troubleshooting and calibration. With the 5 large analog-type gauges the operator can easily identify if key systems are within normal operating range. A resettable trip totals function has been incorporated to display information for average fuel consumed, total fuel consumed, idle fuel, idle time, operating hours, odometer, etc. The navigation buttons are located on the side of the screen and help assist with set up and other various functions.



### Automatic Climate Control and Air Quality

The new climate control system automatically adjusts the air temperature and fan speed to maintain the operator's preferred climate setting. The cab air filtration system recirculates 90% of the cab air and is now serviced from outside the cab, enabling maximum air quality and cab cleanliness. The new air conditioning sealing system keeps refrigerant contained preventing system shutdown. Combined together these systems help the operator to remain efficient and productive all shift long.

### Entry and Exit

Well-placed grab bars and a ladder inclination angle of 10-degrees forward makes the walk into the cab feel more like a staircase than a ladder. When further comfort is needed, an optional retractable ladder provides an inclination of 18-degrees. The new wider front hinged door can be opened and closed while seated, greatly improving ingress and egress. Two new left-hand and right-hand sliding windows can also be opened and closed with one hand while seated for comfortable communication to personnel on the ground.

### Visibility

Visibility has been enhanced by removing the steering wheel, adding a convex windshield, and eliminating two cab posts. The cab has a clean and clear panoramic view for safe operation of the machine. External rearview mirrors are mounted on the cab to provide all around visibility. The external mirrors fold horizontally to provide fast, safe access to clean the window from the front platform. Optional heated and powered mirrors are available to further improve visibility in cold climates.

### Rearview Camera

With the new standard rearview camera, visibility is greatly enhanced. The camera is located in a pocket on the grill to protect it from damage and the elements. The camera can be set to activate only when the transmission is in reverse to help eliminate distractions in the cab, especially when in dark environments. Two rear work lights can be activated to enhance vision in low light conditions.

### Control Panels and Park Brake Switch

Two control panels located on the front right ROPS post consist of large membrane switches making them easy to activate while wearing gloves. The membrane switches contain LED's to denote activation/mode and have a positive feel and "click" to signal activation. The ISO symbols located on each membrane switch are molded all the way through to ensure the image will not wear off over time. A new "help" feature explains the function of each membrane switch. A two position rocker switch activates the electro-hydraulic park brake and is automatically applied upon machine shutdown.



# Serviceability

Easy to Maintain. Easy to Service.



## Electrical Service Center

The electrical service center provides grouped ground level access to numerous electrical features, enhancing safety and convenience for operators and service technicians. It is conveniently located beneath the left platform for access before entering the cab and contains the maintenance free batteries, a fuse relay panel, main disconnect switch, ground level engine shutdown switch, hood tilt switch, and the jump start receptacle.

## Engine Access

The K Series retains the Cat sloped “one-piece” tilting hood, which has become one of our brand’s hallmarks and provides industry-leading access to the engine, Cat Clean Emissions Module (CEM) and other components but with fresh new styling clearly distinct from the H Series. New to the loaders is a rear clamshell hood design that allows quick access to the engine oil dipstick and fill, fuel fill port, and cooler cores.

## Cooling System

The cooling system is readily accessible for clean out and maintenance. With six cooling fins per inch and a perforated grill, most airborne debris entering the system passes through the cooler cores. The cooler cores swing out providing easy access for cleaning; an option variable pitch fan is available to automatically purge the cooler cores by periodically reversing the airflow.

## Hydraulic Service Center

The hydraulic components are all conveniently located behind the hinged right side access ladder at a single ground level service center improving safety and reducing service time. Accessible from the service center are the transmission and hydraulic oil filters, brake accumulators, pressure test ports, etc.



# Sustainability

## Conserving Resources



The 966K is designed to compliment your business plan, reduce emissions and minimize the consumption of natural resources.

- Improved fuel efficiency – less fuel consumed results in lower emissions.
- Machine is built with a 96% recyclability rate (ISO 16714) to conserve valuable natural resources and further enhance machine end-of-life value.
- Engine air filter life doubled to reduce cost and waste.
- Improved operator efficiency through enhanced visibility and reduced noise/vibration levels.
- Product Link family of products and solutions that collect, communicate, store and deliver product and job-site information to maximize productivity and reduce costs.
- Major components are rebuildable, eliminating waste and saving money by giving the machine and/or major components a second – and even third – life.

## Customer Support

Ready to Help. Anytime. Anywhere.

### Machine Selection

Cat dealers are ready to help evaluate machine options; from new or used machine sales, to rental or rebuild options, Cat dealers can provide an optimal solution to meet customer business needs.

### Product Support

Cat dealers are with customers every step of the way to maximize machine uptime by providing unsurpassed worldwide parts support, trained technicians and customer support agreements.

### Operation

To help maximize the return on your investment, Cat dealers offer various training resources to improve operating techniques.

### Financing

Cat dealers offer financing options to meet a variety of customer needs.



# Owning Costs

## Proven Best Investment



### Customer Support Agreements

A Customer Support Agreement (CSA) is an arrangement between you and your Cat dealer that helps you lower your total cost per ton. CSAs are flexible, allowing them to be tailored to your business needs. They can range from simple Preventive Maintenance Kits to elaborate Total Cost Performance Guarantees. Having a CSA with your Cat dealer enables more time for you to do what you do best – run your business.

### Monitoring Systems

Monitoring product health is key to optimizing the life of an investment into a Cat Wheel Loader.

- **Cat Product Link** – Cat Product Link allows remote monitoring of equipment to improve overall fleet-management effectiveness. Product Link is deeply integrated into machine systems. Events and diagnostic codes, as well as hours, fuel, idle time and other detailed information are transmitted to a secure web based application, VisionLink™. VisionLink includes powerful tools to convey information to users and dealers, including mapping, working and idle time, fuel level and more.
- **S.O.S<sup>SM</sup> Services** – Helps manage component life and decrease machine downtime, increasing productivity and efficiency. Regular fluid sampling can help track what is going on inside your machine. Wear related problems are predictable and easily repairable. Maintenance can be done to accommodate your schedule, resulting in increased uptime and flexibility in maintenance repairs before failure.

### Parts Availability

Caterpillar provides an unsurpassed level of personalized service to help you work more cost effective and efficient. By utilizing a worldwide parts network Cat dealers help minimize machine downtime and save money by delivering replacement parts within 24 hours.

### Resale Value

Owning quality equipment is an important factor in maintaining resale value. Caterpillar is not only known for machines that are better built, but provides product and dealer support to maintain the reliability and durability of your machine.



# Operating Costs

## Save Time and Money by Working Smart

Data from customer machines show Cat wheel loaders are among the most fuel efficient machines in the industry. Several features contribute to this excellent fuel efficiency:

- **Performance Series Buckets** – Deliver faster fill times and better material retention, ultimately reducing cycle times while improving productivity and fuel efficiency.
- **Load-Sensing Hydraulics** – Provides only the hydraulic flow required by the implement and steering systems for improved fuel efficiency and greater rimpull.
- **ACERT™ Engine** – Power dense engine enables a more fuel-efficient method to meet emissions regulations.
- **Fuel Management System (FMS)** – Optimizes power for maximum fuel savings with minimal impact on production.
- **Engine Idle Shutdown** – Automatic engine and electrical system shutdown conserves fuel.
- **Torque Converter** – Transfers more power to the ground and optimizes fuel efficiency in all applications.
- **Shift Strategy** – Reduced torque interruption increases driveline efficiency, conserving fuel. Auto 1-4 transmission mode keeps engine rpm low, reducing fuel consumption while delivering optimal machine performance.

Machine configuration, operator technique, and job site layout can impact fuel consumption by as much as 30 percent.

- **Machine Configuration** – Select the correct work tool and tire type based on machine application. Radial tires are preferred; ensure proper inflation pressures. Heavier tires burn more fuel. Keep engine rpm low by using auto 1-4 transmission mode.
- **Job Site Layout** – Spot loading targets in the right position. Avoid traveling more than twice the machine length during short cycle loading. Reduce transport distance for load and carry cycles by optimizing job site layout.
- **Loading Bucket** – Load in first gear and keep engine rpm low. Raise and tilt bucket smoothly and do not use a “pumping” motion. Avoid lift lever detent and use of transmission neutralizer.
- **Loading Truck or Hopper** – Do not raise the work tool any higher than necessary. Keep engine rpm low and unload in controlled manner.
- **Idle** – Set the parking brake to engage Engine Idle Management System.

# 966K Wheel Loader Specifications

Engine		
Engine Model	Cat® C9.3 ACERT™	
Max. Gross Power (1,800 rpm) – SAE J1995	222 kW	296 hp
Max. Gross Power (1,800 rpm) – SAE J1995 (metric)		302 hp
Max. Net Power (1,800 rpm) – ISO 9249	199 kW	267 hp
Max. Net Power (1,800 rpm) – ISO 9249 (metric)		271 hp
Max. Net Power (1,800 rpm) – SAE J1349	199 kW	267 hp
Max. Net Power (1,800 rpm) – SAE J1349 (metric)		271 hp
Max. Net Power (1,800 rpm) – EEC 80/1269	199 kW	267 hp
Max. Net Power (1,800 rpm) – EEC 80/1269 (metric)		271 hp
Peak Gross Torque (1,400 rpm) – SAE J1995	1364 N·m	1,006 ft·lb
Peak Net Torque (1,400 rpm) – SAE J1349	1274 N·m	940 ft·lb
Bore	115 mm	4.5 in
Stroke	149 mm	5.9 in
Displacement	9.3 L	568 in <sup>3</sup>

• Caterpillar engine with ACERT Technology – meets Tier 4 Interim/Stage IIIB emission standards.

Weights		
Operating Weight	24 189 kg	53,311 lb

• For 4.2 m<sup>3</sup> (5.5 yd<sup>3</sup>) general purpose buckets with BOCE.

Buckets		
Bucket Capacities	2.50 m <sup>3</sup> - 9.20 m <sup>3</sup>	3.25 yd <sup>3</sup> - 12.00 yd <sup>3</sup>

• Refer to bucket selection chart.

Operating Specifications		
Static Tipping Load Full 37° Turn – ISO 14397-1*	14 636 kg	32,259 lb
Static Tipping Load Full 37° Turn – Rigid Tires**	15 828 kg	34,886 lb
Breakout Force	173 kN	38,984 lb

• For 4.2 m<sup>3</sup> (5.5 yd<sup>3</sup>) general purpose buckets with BOCE.  
\* Full compliance to ISO (2007) 14397-1 Sections 1 thru 6, which requires 2% verification between calculations and testing.  
\*\* Compliance to ISO (2007) 14397-1 Sections 1 thru 5.

Transmission		
Forward 1	6.7 km/h	4.2 mph
Forward 2	12.6 km/h	7.8 mph
Forward 3	22.4 km/h	13.9 mph
Forward 4	37.4 km/h	23.2 mph
Reverse 1	7.8 km/h	4.9 mph
Reverse 2	13.7 km/h	8.5 mph
Reverse 3	23.5 km/h	14.6 mph
Reverse 4	38.5 km/h	23.9 mph

• Maximum travel speed in standard vehicle with empty bucket and standard L3 tires with 826 mm (33 in) roll radius.

Hydraulic System		
Steering System	Piston	
Pump Type		
Implement System – Maximum Pump Output (2275 rpm)	340 L/min	90 gal/min
Implement System – Maximum Operating Pressure	31 000 kPa	4,496 psi
Implement System – Optional 3rd Function Maximum Flow	300 L/min	79.3 gal/min
Implement System – Optional 3rd Function Maximum Pressure	20 700 kPa	3,000 psi
Hydraulic Cycle Time – Raise from Carry Position	5.9 Seconds	
Hydraulic Cycle Time – Dump, at Maximum Raise	1.5 Seconds	
Hydraulic Cycle Time – Lower, Empty, Float Down	2.4 Seconds	
Hydraulic Cycle Time – Total	9.8 Seconds	

• Cycle time with rated payload.

Brakes	
Brakes	Meet OSHA, SAE J1473 OCT90 and ISO 3450-1985 required standards

## Axles

Front	Fixed	
Rear	Oscillating ±13 degrees	
Maximum Single-Wheel Rise and Fall	495 mm	19.5 in

## Tires

- Choose from a variety of tires to match your application.
- Choices include:
  - 26.5R25 VLT BS E3 Radial
  - 26.5R25 VJT BS E3/L3 Radial
  - 26.5R25 VMT BS L3 Radial
  - 750/65R25 XLD L3T MX L3 Radial
  - 26.5R25 XHA2 MX L3 Radial
  - 26.5R25 XLD D1 MX L4 Radial
  - 26.5R25 VSNT BS E4/L4 Radial
  - 26.5R25 VSDL BS L5 Radial
  - 26.5R25 XLDD2 MX L5 Radial
  - 26.5R25 X MINE D2 MX L5 Radial
- NOTE: In certain applications (such as load and carry), the loader's productive capabilities might exceed the tires' tonnes-km/h (ton-mph) capabilities. Caterpillar recommends that you consult a tire supplier to evaluate all conditions before selecting a tire model. Other special tires are available on request.

## Cab

- |           |                             |
|-----------|-----------------------------|
| ROPS/FOPS | Meets SAE and ISO standards |
|-----------|-----------------------------|
- Cat cab with a four post integrated Rollover Protective Structure (ROPS) are standard in North America and Europe.
  - ROPS meets SAE J1040 APR88 and ISO 3471:1994 criteria.
  - Falling Objects Protective Structure (FOPS) meets SAE J231 JAN81 and ISO:1992 Level II criteria.

## Sound

- The sound values indicated below are for specific operating conditions only. Machine and operator sound levels will vary at different engine and/or cooling fan speeds. Hearing protection may be needed when the machine is operated with a cabin that is not properly maintained, or when the doors and/or windows are open for extended periods or in a noisy environment.
- The dynamic operator sound pressure level for a standard machine configuration, measured according to the procedures specified in "ISO 6396:2008," is 69 dB(A) with a cooling fan speed set at 70 percent of the maximum value.
- The sound power level that is labeled on the machine is 108 LWA. The measurement of the sound power level was made according to the test procedures and conditions that are specified in the European Union Directive "2000/14/EC" as amended by "2005/88/EC."

## Service Refill Capacities

Fuel Tank – Standard	381 L	101 gal
Cooling System	65 L	17.2 gal
Crankcase	24.5 L	6.5 gal
Transmission	50 L	13.2 gal
Differentials and Final Drives – Front	64 L	16.9 gal
Differentials and Final Drives – Rear	64 L	16.9 gal
Hydraulic Tank	198 L	52.3 gal

# 966K Wheel Loader Specifications

## Dimensions

All dimensions are approximate and based on L3 Michelin XHA2 tires.

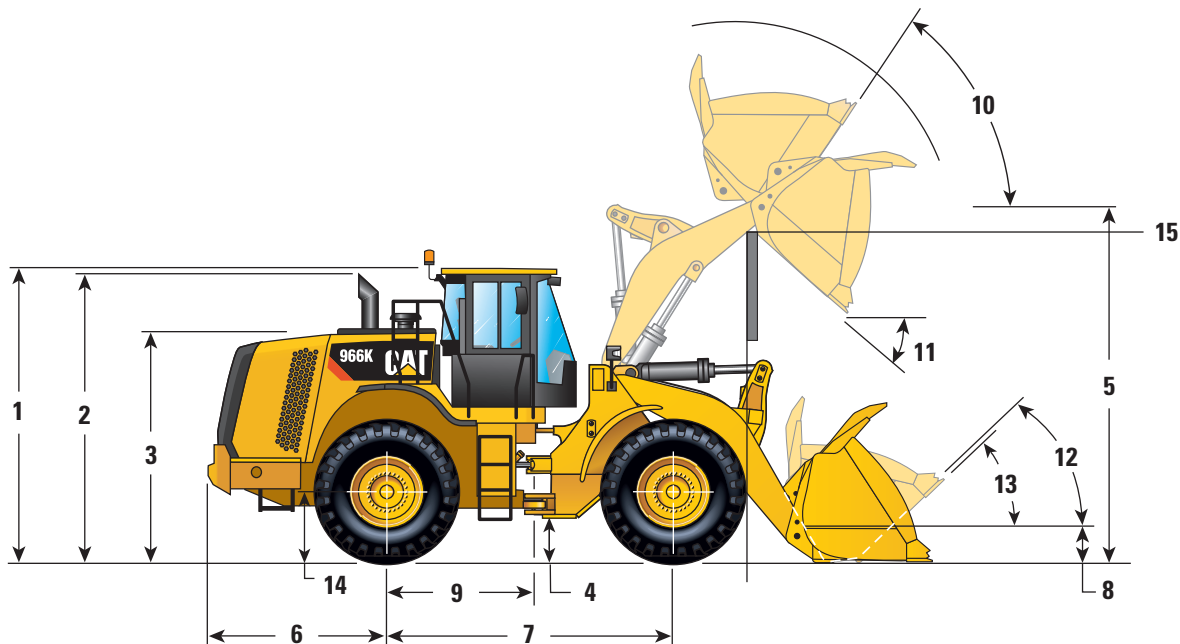

<b>1</b> Height to Top of ROPS	3547 mm	11'7"
<b>2</b> Height to Top of Exhaust Pipe	3518 mm	11'6"
<b>3</b> Height to Top of Hood	2828 mm	9'3"
<b>4</b> Ground Clearance With 26.5R25 (See Tire Option Chart for Other Tires)	475 mm	1'6"
<b>5</b> B-Pin Height – Standard	4234 mm	13'10"
B-Pin Height – High-Lift	4792 mm	15'8"
<b>6</b> Center Line of Rear Axle to Edge of Counterweight	2187 mm	7'2"
<b>7</b> Wheelbase	3450 mm	11'3"
<b>8</b> B-Pin Height @ Carry – Standard	640 mm	2'1"
<b>9</b> Center Line of Rear Axle to Hitch	1725 mm	5'7"
<b>10</b> Rack Back @ Maximum Lift		62 degrees
<b>11</b> Dump Angle @ Maximum Lift		49 degrees
<b>12</b> Rack Back @ Carry		50 degrees
<b>13</b> Rack Back @ Ground		42 degrees
<b>14</b> Height to Center Line of Axle	798 mm	2'7"
<b>15</b> Lift Arm Clearance	2862 mm	9'3"
Lift Arm Clearance @ High Lift	4153 mm	13'6"



## Operating Specifications

Bucket Type		Material Handling – Pin On					
		Bolt-On Edges	Teeth and Segments	Bolt-On Edges	Teeth and Segments	Bolt-On Edges	Teeth and Segments
Capacity – Rated (§)	m <sup>3</sup>	4.00	4.00	4.20	4.20	4.40	4.40
	yd <sup>3</sup>	5.23	5.23	5.49	5.49	5.75	5.75
Capacity – Struck (§)	m <sup>3</sup>	3.40	3.40	3.40	3.40	3.76	3.76
	yd <sup>3</sup>	4.45	4.45	4.45	4.45	4.92	4.92
Width (§)	mm	3220	3271	3220	3271	3220	3271
	ft/in	10'6"	10'8"	10'6"	10'8"	10'6"	10'8"
Dump Clearance at Maximum Lift and 45° Discharge (§)	mm	2978	2815	2949	2787	2921	2758
	ft/in	9'9"	9'2"	9'8"	9'1"	9'7"	9'0"
Reach at Maximum Lift and 45° Discharge (§)	mm	1252	1379	1280	1407	1309	1436
	ft/in	4'1"	4'6"	4'2"	4'7"	4'3"	4'8"
Reach at Level Lift Arm and Bucket Level (§)	mm	2769	2973	2809	3013	2849	3053
	ft/in	9'1"	9'9"	9'2"	9'10"	9'4"	10'0"
Digging Depth (§)	mm	124	124	124	124	124	124
	in	4.9"	4.9"	4.9"	4.9"	4.9"	4.9"
Overall Length	mm	8622	8847	8662	8887	8702	8927
	ft/in	28'4"	29'1"	28'5"	29'2"	28'7"	29'4"
Overall Height with Bucket at Maximum Lift	mm	5858	5858	5901	5901	5931	5931
	ft/in	19'3"	19'3"	19'5"	19'5"	19'6"	19'6"
Loader Clearance Circle with Bucket at Carry Position (§)	mm	14 742	14 914	14 763	14 935	14 783	14 956
	ft/in	48'5"	49'0"	48'6"	49'0"	48'6"	49'1"
Static Tipping Load, Straight (ISO)*	kg	16 632	16 452	16 561	16 380	16 481	16 300
	lb	36,657	36,260	36,501	36,102	36,326	35,925
Static Tipping Load, Straight (Rigid Tire)*	kg	17 824	17 641	17 760	17 575	17 686	17 501
	lb	39,286	38,881	39,143	38,736	38,980	38,572
Static Tipping Load, Articulated (ISO)*	kg	14 644	14 462	14 575	14 392	14 497	14 313
	lb	32,276	31,875	32,123	31,721	31,951	31,547
Static Tipping Load, Articulated (Rigid Tire)*	kg	15 810	15 627	15 747	15 563	15 675	15 490
	lb	34,846	34,442	34,707	34,301	34,549	34,140
Breakout Force** (§)	kN	182	181	177	175	171	170
	lb	41,111	40,742	39,834	39,468	38,618	38,253
Operating Weight*	kg	24 141	24 279	24 186	24 324	24 239	24 377
	lb	53,207	53,511	53,305	53,609	53,422	53,726

\* Static tipping loads and operating weights shown are based on a machine configuration with Michelin 26.5R25 XHA2 L3 Radial tires, full fluids, operator, standard counterweight, cold start, roading fenders, Product Link, open differential axles (front/rear), power train guard, secondary steering, and sound suppression.

\*\* Measured 102 mm (4") behind tip of cutting edge with bucket hinge pin as pivot point in accordance with SAE J732C.

\*\*\* Rock bucket specifications are given on Michelin 26.5R25 XLDD2 L5 Radial tires.

\*\*\*\* Roading bucket specifications are based on a machine configuration with Michelin 26.5R25 XHA2 L3 Radial tires, full fluids, operator, roading counterweight, roading fenders, Product Link, limited slip differential axles (front/rear), power train guard, secondary steering, and sound suppression.

(§) Specifications and ratings conform to all applicable standards recommended by the Society of Automotive Engineers, including SAE Standard J732C governing loader ratings.

(ISO) Full compliance to ISO 14397-1 (2007) Sections 1 thru 6, which requires 2% verification between calculations and testing.

(Rigid Tire) Compliance to ISO 14397-1 (2007) Sections 1 thru 5.

# 966K Wheel Loader Specifications

## Operating Specifications

Bucket Type		Material Handling – Pin On				Material Handling – Fusion QC	
		Bolt-On Edges	Teeth and Segments	Bolt-On Edges	Teeth and Segments	Bolt-On Edges	Teeth and Segments
Capacity – Rated (§)	m <sup>3</sup>	4.60	4.60	4.80	4.80	4.00	4.00
	yd <sup>3</sup>	6.02	6.02	6.28	6.28	5.23	5.23
Capacity – Struck (§)	m <sup>3</sup>	3.93	3.93	4.11	4.11	3.40	3.40
	yd <sup>3</sup>	5.14	5.14	5.38	5.38	4.45	4.45
Width (§)	mm	3220	3271	3220	3271	3220	3271
	ft/in	10'6"	10'8"	10'6"	10'8"	10'6"	10'8"
Dump Clearance at Maximum Lift and 45° Discharge (§)	mm	2893	2730	2865	2702	2927	2765
	ft/in	9'5"	8'11"	9'4"	8'10"	9'7"	9'0"
Reach at Maximum Lift and 45° Discharge (§)	mm	1337	1464	1365	1492	1302	1429
	ft/in	4'4"	4'9"	4'5"	4'10"	4'3"	4'8"
Reach at Level Lift Arm and Bucket Level (§)	mm	2889	3093	2929	3133	2840	3045
	ft/in	9'5"	10'1"	9'7"	10'3"	9'3"	9'11"
Digging Depth (§)	mm	124	124	124	124	124	124
	in	4.9"	4.9"	4.9"	4.9"	4.9"	4.9"
Overall Length	mm	8742	8967	8782	9007	8693	8918
	ft/in	28'9"	29'6"	28'10"	29'7"	28'7"	29'4"
Overall Height with Bucket at Maximum Lift	mm	5982	5982	6023	6023	5900	5900
	ft/in	19'8"	19'8"	19'10"	19'10"	19'5"	19'5"
Loader Clearance Circle with Bucket at Carry Position (§)	mm	14 804	14 978	14 825	14 999	14 772	14 947
	ft/in	48'7"	49'2"	48'8"	49'3"	48'6"	49'1"
Static Tipping Load, Straight (ISO)*	kg	16 420	16 237	16 347	16 164	15 974	15 795
	lb	36,190	35,787	36,030	35,625	35,208	34,813
Static Tipping Load, Straight (Rigid Tire)*	kg	17 630	17 444	17 564	17 376	17 150	16 967
	lb	38,858	38,447	38,711	38,298	37,799	37,396
Static Tipping Load, Articulated (ISO)*	kg	14 437	14 252	14 366	14 181	14 012	13 831
	lb	31,819	31,413	31,664	31,255	30,883	30,483
Static Tipping Load, Articulated (Rigid Tire)*	kg	15 621	15 435	15 556	15 369	15 165	14 982
	lb	34,429	34,019	34,287	33,874	33,425	33,022
Breakout Force** (§)	kN	166	165	161	160	172	171
	lb	37,481	37,117	36,391	36,029	38,836	38,470
Operating Weight*	kg	24 274	24 412	24 320	24 458	24 601	24 739
	lb	53,499	53,803	53,600	53,904	54,219	54,523

\* Static tipping loads and operating weights shown are based on a machine configuration with Michelin 26.5R25 XHA2 L3 Radial tires, full fluids, operator, standard counterweight, cold start, roading fenders, Product Link, open differential axles (front/rear), power train guard, secondary steering, and sound suppression.

\*\* Measured 102 mm (4") behind tip of cutting edge with bucket hinge pin as pivot point in accordance with SAE J732C.

\*\*\* Rock bucket specifications are given on Michelin 26.5R25 XLDD2 L5 Radial tires.

\*\*\*\* Roading bucket specifications are based on a machine configuration with Michelin 26.5R25 XHA2 L3 Radial tires, full fluids, operator, roading counterweight, roading fenders, Product Link, limited slip differential axles (front/rear), power train guard, secondary steering, and sound suppression.

(§) Specifications and ratings conform to all applicable standards recommended by the Society of Automotive Engineers, including SAE Standard J732C governing loader ratings.

(ISO) Full compliance to ISO 14397-1 (2007) Sections 1 thru 6, which requires 2% verification between calculations and testing.

(Rigid Tire) Compliance to ISO 14397-1 (2007) Sections 1 thru 5.

## Operating Specifications

Bucket Type		Material Handling – Fusion QC					
		Bolt-On Edges	Teeth and Segments	Bolt-On Edges	Teeth and Segments	Bolt-On Edges	Teeth and Segments
Capacity – Rated (§)	m <sup>3</sup>	4.20	4.20	4.40	4.40	4.60	4.60
	yd <sup>3</sup>	5.49	5.49	5.75	5.75	6.02	6.02
Capacity – Struck (§)	m <sup>3</sup>	3.40	3.40	3.76	3.76	3.93	3.93
	yd <sup>3</sup>	4.45	4.45	4.92	4.92	5.14	5.14
Width (§)	mm	3220	3271	3220	3271	3220	3271
	ft/in	10'6"	10'8"	10'6"	10'8"	10'6"	10'8"
Dump Clearance at Maximum Lift and 45° Discharge (§)	mm	2899	2736	2872	2709	2843	2680
	ft/in	9'6"	8'11"	9'5"	8'10"	9'3"	8'9"
Reach at Maximum Lift and 45° Discharge (§)	mm	1331	1458	1358	1485	1387	1514
	ft/in	4'4"	4'9"	4'5"	4'10"	4'6"	4'11"
Reach at Level Lift Arm and Bucket Level (§)	mm	2880	3085	2919	3123	2960	3165
	ft/in	9'5"	10'1"	9'6"	10'2"	9'8"	10'4"
Digging Depth (§)	mm	124	124	124	124	124	124
	in	4.9"	4.9"	4.9"	4.9"	4.9"	4.9"
Overall Length	mm	8733	8958	8772	8997	8813	9038
	ft/in	28'8"	29'5"	28'10"	29'7"	28'11"	29'8"
Overall Height with Bucket at Maximum Lift	mm	5943	5943	5973	5973	6024	6024
	ft/in	19'6"	19'6"	19'8"	19'8"	19'10"	19'10"
Loader Clearance Circle with Bucket at Carry Position (§)	mm	14 793	14 969	14 814	14 990	14 836	15 013
	ft/in	48'7"	49'2"	48'8"	49'3"	48'9"	49'4"
Static Tipping Load, Straight (ISO)*	kg	15 903	15 722	15 828	15 647	15 760	15 577
	lb	35,050	34,652	34,885	34,486	34,735	34,333
Static Tipping Load, Straight (Rigid Tire)*	kg	17 084	16 900	17 015	16 830	16 952	16 766
	lb	37,653	37,248	37,501	37,094	37,362	36,953
Static Tipping Load, Articulated (ISO)*	kg	13 942	13 760	13 868	13 685	13 802	13 618
	lb	30,728	30,327	30,565	30,162	30,420	30,015
Static Tipping Load, Articulated (Rigid Tire)*	kg	15 101	14 917	15 033	14 848	14 972	14 786
	lb	33,283	32,878	33,133	32,725	32,999	32,589
Breakout Force** (§)	kN	167	166	162	161	158	156
	lb	37,675	37,311	36,600	36,238	35,526	35,165
Operating Weight*	kg	24 647	24 785	24 701	24 839	24 738	24 876
	lb	54,321	54,625	54,441	54,745	54,523	54,827

\* Static tipping loads and operating weights shown are based on a machine configuration with Michelin 26.5R25 XHA2 L3 Radial tires, full fluids, operator, standard counterweight, cold start, roading fenders, Product Link, open differential axles (front/rear), power train guard, secondary steering, and sound suppression.

\*\* Measured 102 mm (4") behind tip of cutting edge with bucket hinge pin as pivot point in accordance with SAE J732C.

\*\*\* Rock bucket specifications are given on Michelin 26.5R25 XLDD2 L5 Radial tires.

\*\*\*\* Roading bucket specifications are based on a machine configuration with Michelin 26.5R25 XHA2 L3 Radial tires, full fluids, operator, roading counterweight, roading fenders, Product Link, limited slip differential axles (front/rear), power train guard, secondary steering, and sound suppression.

(§) Specifications and ratings conform to all applicable standards recommended by the Society of Automotive Engineers, including SAE Standard J732C governing loader ratings.

(ISO) Full compliance to ISO 14397-1 (2007) Sections 1 thru 6, which requires 2% verification between calculations and testing.

(Rigid Tire) Compliance to ISO 14397-1 (2007) Sections 1 thru 5.

# 966K Wheel Loader Specifications

## Operating Specifications

Bucket Type		Material Handling – Fusion QC		Heavy Duty Material Handling – Pin On			
		Bolt-On Edges	Teeth and Segments	Bolt-On Edges	Teeth and Segments	Bolt-On Edges	Teeth and Segments
Capacity – Rated (§)	m <sup>3</sup>	4.80	4.80	4.20	4.20	4.60	4.60
	yd <sup>3</sup>	6.28	6.28	5.49	5.49	6.02	6.02
Capacity – Struck (§)	m <sup>3</sup>	4.11	4.11	3.40	3.40	3.93	3.93
	yd <sup>3</sup>	5.38	5.38	4.45	4.45	5.14	5.14
Width (§)	mm	3220	3271	3220	3271	3220	3271
	ft/in	10'6"	10'8"	10'6"	10'8"	10'6"	10'8"
Dump Clearance at Maximum Lift and 45° Discharge (§)	mm	2814	2651	2949	2787	2893	2730
	ft/in	9'2"	8'8"	9'8"	9'1"	9'5"	8'11"
Reach at Maximum Lift and 45° Discharge (§)	mm	1416	1543	1280	1407	1337	1464
	ft/in	4'7"	5'0"	4'2"	4'7"	4'4"	4'9"
Reach at Level Lift Arm and Bucket Level (§)	mm	3000	3205	2809	3013	2889	3093
	ft/in	9'10"	10'6"	9'2"	9'10"	9'5"	10'1"
Digging Depth (§)	mm	124	124	124	124	124	124
	in	4.9"	4.9"	4.9"	4.9"	4.9"	4.9"
Overall Length	mm	8853	9078	8662	8887	8742	8967
	ft/in	29'1"	29'10"	28'5"	29'2"	28'9"	29'6"
Overall Height with Bucket at Maximum Lift	mm	6066	6066	5901	5901	5982	5982
	ft/in	19'11"	19'11"	19'5"	19'5"	19'8"	19'8"
Loader Clearance Circle with Bucket at Carry Position (§)	mm	14 857	15 035	14 763	14 935	14 804	14 978
	ft/in	48'9"	49'4"	48'6"	49'0"	48'7"	49'2"
Static Tipping Load, Straight (ISO)*	kg	15 686	15 503	16 446	16 265	16 272	16 089
	lb	34,573	34,170	36,247	35,848	35,865	35,462
Static Tipping Load, Straight (Rigid Tire)*	kg	16 884	16 697	17 643	17 459	17 481	17 294
	lb	37,213	36,801	38,886	38,479	38,528	38,117
Static Tipping Load, Articulated (ISO)*	kg	13 730	13 546	14 458	14 276	14 288	14 103
	lb	30,262	29,855	31,867	31,464	31,491	31,085
Static Tipping Load, Articulated (Rigid Tire)*	kg	14 906	14 719	15 630	15 446	15 471	15 285
	lb	32,853	32,441	34,450	34,044	34,100	33,689
Breakout Force** (§)	kN	153	152	176	175	166	164
	lb	34,526	34,166	39,730	39,363	37,341	36,977
Operating Weight*	kg	24 786	24 924	24 304	24 442	24 419	24 557
	lb	54,628	54,932	53,566	53,870	53,820	54,124

\* Static tipping loads and operating weights shown are based on a machine configuration with Michelin 26.5R25 XHA2 L3 Radial tires, full fluids, operator, standard counterweight, cold start, roading fenders, Product Link, open differential axles (front/rear), power train guard, secondary steering, and sound suppression.

\*\* Measured 102 mm (4") behind tip of cutting edge with bucket hinge pin as pivot point in accordance with SAE J732C.

\*\*\* Rock bucket specifications are given on Michelin 26.5R25 XLDD2 L5 Radial tires.

\*\*\*\* Roading bucket specifications are based on a machine configuration with Michelin 26.5R25 XHA2 L3 Radial tires, full fluids, operator, roading counterweight, roading fenders, Product Link, limited slip differential axles (front/rear), power train guard, secondary steering, and sound suppression.

(§) Specifications and ratings conform to all applicable standards recommended by the Society of Automotive Engineers, including SAE Standard J732C governing loader ratings.

(ISO) Full compliance to ISO 14397-1 (2007) Sections 1 thru 6, which requires 2% verification between calculations and testing.

(Rigid Tire) Compliance to ISO 14397-1 (2007) Sections 1 thru 5.

## Operating Specifications

Bucket Type		Heavy Duty Material Handling – Pin On		Material Handling with Backgrading Edge – Pin On		General Purpose – Pin On	
		Bolt-On Edges	Teeth and Segments	Teeth	Teeth	Bolt-On Edges	Teeth and Segments
Capacity – Rated (§)	m <sup>3</sup>	4.80	4.80	4.60	4.20	3.80	3.80
	yd <sup>3</sup>	6.28	6.28	6.02	5.49	4.97	4.97
Capacity – Struck (§)	m <sup>3</sup>	4.11	4.11	4.03	3.66	3.24	3.24
	yd <sup>3</sup>	5.38	5.38	5.27	4.79	4.24	4.24
Width (§)	mm	3220	3271	3201	3201	3220	3271
	ft/in	10'6"	10'8"	10'6"	10'6"	10'6"	10'8"
Dump Clearance at Maximum Lift and 45° Discharge (§)	mm	2865	2702	2944	3001	3067	2915
	ft/in	9'4"	8'10"	9'7"	9'10"	10'0"	9'6"
Reach at Maximum Lift and 45° Discharge (§)	mm	1365	1492	1328	1271	1327	1467
	ft/in	4'5"	4'10"	4'4"	4'2"	4'4"	4'9"
Reach at Level Lift Arm and Bucket Level (§)	mm	2929	3133	2846	2766	2739	2943
	ft/in	9'7"	10'3"	9'4"	9'0"	8'11"	9'7"
Digging Depth (§)	mm	124	124	94	94	124	124
	in	4.9"	4.9"	3.7"	3.7"	4.9"	4.9"
Overall Length	mm	8782	9007	8674	8594	8592	8817
	ft/in	28'10"	29'7"	28'6"	28'3"	28'3"	29'0"
Overall Height with Bucket at Maximum Lift	mm	6023	6023	6023	5940	5788	5788
	ft/in	19'10"	19'10"	19'10"	19'6"	19'0"	19'0"
Loader Clearance Circle with Bucket at Carry Position (§)	mm	14 825	14 999	14 741	14 700	14 727	14 899
	ft/in	48'8"	49'3"	48'5"	48'3"	48'4"	48'11"
Static Tipping Load, Straight (ISO)*	kg	16 193	16 009	15 961	16 135	16 852	16 671
	lb	35,690	35,285	35,179	35,562	37,142	36,743
Static Tipping Load, Straight (Rigid Tire)*	kg	17 407	17 219	17 176	17 340	18 071	17 886
	lb	38,365	37,952	37,857	38,217	39,829	39,422
Static Tipping Load, Articulated (ISO)*	kg	14 210	14 025	13 961	14 131	14 843	14 661
	lb	31,320	30,911	30,770	31,146	32,715	32,312
Static Tipping Load, Articulated (Rigid Tire)*	kg	15 399	15 212	15 154	15 313	16 034	15 849
	lb	33,941	33,528	33,400	33,751	35,339	34,932
Breakout Force** (§)	kN	161	159	169	180	187	185
	lb	36,244	35,883	38,109	40,621	42,151	41,781
Operating Weight*	kg	24 472	24 610	24 789	24 675	24 081	24 218
	lb	53,935	54,239	54,634	54,383	53,073	53,377

\* Static tipping loads and operating weights shown are based on a machine configuration with Michelin 26.5R25 XHA2 L3 Radial tires, full fluids, operator, standard counterweight, cold start, roading fenders, Product Link, open differential axles (front/rear), power train guard, secondary steering, and sound suppression.

\*\* Measured 102 mm (4") behind tip of cutting edge with bucket hinge pin as pivot point in accordance with SAE J732C.

\*\*\* Rock bucket specifications are given on Michelin 26.5R25 XLDD2 L5 Radial tires.

\*\*\*\* Roading bucket specifications are based on a machine configuration with Michelin 26.5R25 XHA2 L3 Radial tires, full fluids, operator, roading counterweight, roading fenders, Product Link, limited slip differential axles (front/rear), power train guard, secondary steering, and sound suppression.

(§) Specifications and ratings conform to all applicable standards recommended by the Society of Automotive Engineers, including SAE Standard J732C governing loader ratings.

(ISO) Full compliance to ISO 14397-1 (2007) Sections 1 thru 6, which requires 2% verification between calculations and testing.

(Rigid Tire) Compliance to ISO 14397-1 (2007) Sections 1 thru 5.

# 966K Wheel Loader Specifications

## Operating Specifications

Bucket Type		General Purpose – Pin On					
		Bolt-On Edges	Teeth and Segments	Bolt-On Edges	Teeth and Segments	Bolt-On Edges	Teeth and Segments
Capacity – Rated (§)	m <sup>3</sup>	4.00	4.00	4.20	4.20	4.60	4.60
	yd <sup>3</sup>	5.23	5.23	5.49	5.49	6.02	6.02
Capacity – Struck (§)	m <sup>3</sup>	3.50	3.50	3.80	3.80	4.05	4.05
	yd <sup>3</sup>	4.58	4.58	4.97	4.97	5.30	5.30
Width (§)	mm	3220	3271	3220	3271	3220	3271
	ft/in	10'6"	10'8"	10'6"	10'8"	10'6"	10'8"
Dump Clearance at Maximum Lift and 45° Discharge (§)	mm	3058	2905	2991	2837	2977	2823
	ft/in	10'0"	9'6"	9'9"	9'3"	9'9"	9'3"
Reach at Maximum Lift and 45° Discharge (§)	mm	1334	1473	1388	1525	1400	1537
	ft/in	4'4"	4'10"	4'6"	5'0"	4'7"	5'0"
Reach at Level Lift Arm and Bucket Level (§)	mm	2750	2955	2838	3043	2857	3062
	ft/in	9'0"	9'8"	9'3"	9'11"	9'4"	10'0"
Digging Depth (§)	mm	124	124	124	124	124	124
	in	4.9"	4.9"	4.9"	4.9"	4.9"	4.9"
Overall Length	mm	8604	8829	8691	8916	8710	8935
	ft/in	28'3"	29'0"	28'7"	29'4"	28'7"	29'4"
Overall Height with Bucket at Maximum Lift	mm	5902	5902	5902	5902	5874	5874
	ft/in	19'5"	19'5"	19'5"	19'5"	19'4"	19'4"
Loader Clearance Circle with Bucket at Carry Position (§)	mm	14 733	14 905	14 778	14 951	14 787	14 961
	ft/in	48'5"	48'11"	48'6"	49'1"	48'7"	49'1"
Static Tipping Load, Straight (ISO)*	kg	16 833	16 652	16 635	16 453	16 631	16 447
	lb	37,101	36,701	36,664	36,262	36,655	36,249
Static Tipping Load, Straight (Rigid Tire)*	kg	18 062	17 877	17 855	17 669	17 875	17 687
	lb	39,809	39,401	39,353	38,943	39,397	38,983
Static Tipping Load, Articulated (ISO)*	kg	14 821	14 638	14 636	14 452	14 622	14 436
	lb	32,666	32,262	32,259	31,853	32,227	31,817
Static Tipping Load, Articulated (Rigid Tire)*	kg	16 021	15 836	15 828	15 642	15 837	15 649
	lb	35,311	34,903	34,886	34,476	34,906	34,492
Breakout Force** (§)	kN	185	183	173	171	170	168
	lb	41,695	41,326	38,984	38,618	38,277	37,912
Operating Weight*	kg	24 133	24 270	24 189	24 326	24 229	24 366
	lb	53,188	53,492	53,311	53,615	53,399	53,703

\* Static tipping loads and operating weights shown are based on a machine configuration with Michelin 26.5R25 XHA2 L3 Radial tires, full fluids, operator, standard counterweight, cold start, roading fenders, Product Link, open differential axles (front/rear), power train guard, secondary steering, and sound suppression.

\*\* Measured 102 mm (4") behind tip of cutting edge with bucket hinge pin as pivot point in accordance with SAE J732C.

\*\*\* Rock bucket specifications are given on Michelin 26.5R25 XLDD2 L5 Radial tires.

\*\*\*\* Roading bucket specifications are based on a machine configuration with Michelin 26.5R25 XHA2 L3 Radial tires, full fluids, operator, roading counterweight, roading fenders, Product Link, limited slip differential axles (front/rear), power train guard, secondary steering, and sound suppression.

(§) Specifications and ratings conform to all applicable standards recommended by the Society of Automotive Engineers, including SAE Standard J732C governing loader ratings.

(ISO) Full compliance to ISO 14397-1 (2007) Sections 1 thru 6, which requires 2% verification between calculations and testing.

(Rigid Tire) Compliance to ISO 14397-1 (2007) Sections 1 thru 5.

## Operating Specifications

Bucket Type		General Purpose – Fusion QC					
		Bolt-On Edges	Teeth and Segments	Bolt-On Edges	Teeth and Segments	Bolt-On Edges	Teeth and Segments
Capacity – Rated (§)	m <sup>3</sup>	3.80	3.80	4.20	4.20	4.60	4.60
	yd <sup>3</sup>	4.97	4.97	5.49	5.49	6.02	6.02
Capacity – Struck (§)	m <sup>3</sup>	3.24	3.24	3.80	3.80	4.05	4.05
	yd <sup>3</sup>	4.24	4.24	4.97	4.97	5.30	5.30
Width (§)	mm	3220	3271	3220	3271	3220	3271
	ft/in	10'6"	10'8"	10'6"	10'8"	10'6"	10'8"
Dump Clearance at Maximum Lift and 45° Discharge (§)	mm	3038	2886	2960	2806	2947	2793
	ft/in	9'11"	9'5"	9'8"	9'2"	9'8"	9'1"
Reach at Maximum Lift and 45° Discharge (§)	mm	1362	1501	1433	1571	1436	1573
	ft/in	4'5"	4'11"	4'8"	5'1"	4'8"	5'1"
Reach at Level Lift Arm and Bucket Level (§)	mm	2783	2988	2893	3097	2903	3108
	ft/in	9'1"	9'9"	9'5"	10'1"	9'6"	10'2"
Digging Depth (§)	mm	124	124	116	116	123	123
	in	4.9"	4.9"	4.5"	4.5"	4.8"	4.8"
Overall Length	mm	8637	8862	8739	8965	8755	8980
	ft/in	28'5"	29'1"	28'9"	29'5"	28'9"	29'6"
Overall Height with Bucket at Maximum Lift	mm	5803	5803	5960	5960	6038	6038
	ft/in	19'1"	19'1"	19'7"	19'7"	19'10"	19'10"
Loader Clearance Circle with Bucket at Carry Position (§)	mm	14 743	14 917	14 794	14 970	14 804	14 981
	ft/in	48'5"	49'0"	48'7"	49'2"	48'7"	49'2"
Static Tipping Load, Straight (ISO)*	kg	16 279	16 099	16 015	15 834	16 131	15 947
	lb	35,880	35,483	35,297	34,898	35,553	35,148
Static Tipping Load, Straight (Rigid Tire)*	kg	17 471	17 287	17 204	17 020	17 364	17 176
	lb	38,506	38,101	37,918	37,512	38,271	37,857
Static Tipping Load, Articulated (ISO)*	kg	14 292	14 111	14 047	13 865	14 136	13 950
	lb	31,501	31,100	30,961	30,558	31,156	30,747
Static Tipping Load, Articulated (Rigid Tire)*	kg	15 460	15 276	15 214	15 029	15 344	15 156
	lb	34,074	33,670	33,531	33,125	33,819	33,405
Breakout Force** (§)	kN	180	179	166	164	164	163
	lb	40,632	40,264	37,382	37,023	37,007	36,644
Operating Weight*	kg	24 498	24 636	24 561	24 699	24 675	24 813
	lb	53,992	54,296	54,132	54,436	54,383	54,687

\* Static tipping loads and operating weights shown are based on a machine configuration with Michelin 26.5R25 XHA2 L3 Radial tires, full fluids, operator, standard counterweight, cold start, roading fenders, Product Link, open differential axles (front/rear), power train guard, secondary steering, and sound suppression.

\*\* Measured 102 mm (4") behind tip of cutting edge with bucket hinge pin as pivot point in accordance with SAE J732C.

\*\*\* Rock bucket specifications are given on Michelin 26.5R25 XLDD2 L5 Radial tires.

\*\*\*\* Roading bucket specifications are based on a machine configuration with Michelin 26.5R25 XHA2 L3 Radial tires, full fluids, operator, roading counterweight, roading fenders, Product Link, limited slip differential axles (front/rear), power train guard, secondary steering, and sound suppression.

(§) Specifications and ratings conform to all applicable standards recommended by the Society of Automotive Engineers, including SAE Standard J732C governing loader ratings.

(ISO) Full compliance to ISO 14397-1 (2007) Sections 1 thru 6, which requires 2% verification between calculations and testing.

(Rigid Tire) Compliance to ISO 14397-1 (2007) Sections 1 thru 5.

# 966K Wheel Loader Specifications

## Operating Specifications

Bucket Type		Rock – Pin On ***		Light Material – Pin On	Light Material – Fusion QC	Roading Specifications****		High Lift Change in Specs
		Bolt-On Edges	Teeth and Segments	Bolt-On Edges	Bolt-On Edges	Material Handling with Backgrading Edge – Pin On	Material Handling – Pin On	
Edge Type		Bolt-On Edges	Teeth and Segments	Bolt-On Edges	Bolt-On Edges	Teeth	Bolt-On Edges	
Capacity – Rated (\$)	m <sup>3</sup>	3.40	3.40	7.10	7.10	4.20	4.20	
	yd <sup>3</sup>	4.45	4.45	9.29	9.29	5.49	5.49	
Capacity – Struck (\$)	m <sup>3</sup>	2.90	2.90	6.20	6.20	3.56	3.70	
	yd <sup>3</sup>	3.79	3.79	8.11	8.11	4.66	4.84	
Width (\$)	mm	3252	3252	3447	3447	3000	2995	
	ft/in	10'8"	10'8"	11'3"	11'3"	9'10"	9'9"	
Dump Clearance at Maximum Lift and 45° Discharge (\$)	mm	3124	3026	2625	2597	3020	2969	558
	ft/in	10'2"	9'11"	8'7"	8'6"	9'10"	9'8"	1'9"
Reach at Maximum Lift and 45° Discharge (\$)	mm	1454	1576	1583	1630	1428	1441	
	ft/in	4'9"	5'2"	5'2"	5'4"	4'8"	4'8"	
Reach at Level Lift Arm and Bucket Level (\$)	mm	2818	2974	3252	3305	2846	2889	404
	ft/in	9'2"	9'9"	10'8"	10'10"	9'4"	9'5"	1'3"
Digging Depth (\$)	mm	68	68	140	126	94	124	-25
	in	2.7"	2.7"	5.5"	4.9"	3.7"	4.9"	-1"
Overall Length	mm	8656	8817	9117	9160	8652	8720	788
	ft/in	28'5"	28'12"	29'11"	30'1"	28'5"	28'8"	2'7"
Overall Height with Bucket at Maximum Lift	mm	5845	5845	6071	6311	5939	5939	559
	ft/in	19'3"	19'3"	19'11"	20'9"	19'6"	19'6"	1'10"
Loader Clearance Circle with Bucket at Carry Position (\$)	mm	14 813	14 901	15 214	15 232	14 557	14 598	481
	ft/in	48'8"	48'11"	49'11"	50'0"	47'10"	47'11"	1'7"
Static Tipping Load, Straight (ISO)*	kg	17 057	16 988	15 930	15 134	16 271	16 177	170
	lb	37,594	37,441	35,111	33,357	35,863	35,655	376
Static Tipping Load, Straight (Rigid Tire)*	kg	18 293	18 222	17 192	16 375	17 431	17 328	115
	lb	40,318	40,162	37,891	36,091	38,419	38,192	254
Static Tipping Load, Articulated (ISO)*	kg	15 004	14 934	13 955	13 180	14 365	14 278	-11
	lb	33,068	32,914	30,757	29,048	31,660	31,470	-26
Static Tipping Load, Articulated (Rigid Tire)*	kg	16 213	16 142	15 189	14 399	15 495	15 400	-54
	lb	35,734	35,578	33,478	31,736	34,151	33,943	-120
Breakout Force** (\$)	kN	186	185	129	124	173	168	-14
	lb	41,828	41,704	29,095	27,969	39,033	37,813	-3,167
Operating Weight*	kg	25 011	25 063	24 496	25 130	23 518	23 533	1726
	lb	55,125	55,239	53,989	55,387	51,832	51,866	3,803

\* Static tipping loads and operating weights shown are based on a machine configuration with Michelin 26.5R25 XHA2 L3 Radial tires, full fluids, operator, standard counterweight, cold start, roading fenders, Product Link, open differential axles (front/rear), power train guard, secondary steering, and sound suppression.

\*\* Measured 102 mm (4") behind tip of cutting edge with bucket hinge pin as pivot point in accordance with SAE J732C.

\*\*\* Rock bucket specifications are given on Michelin 26.5R25 XLDD2 L5 Radial tires.

\*\*\*\* Roading bucket specifications are based on a machine configuration with Michelin 26.5R25 XHA2 L3 Radial tires, full fluids, operator, roading counterweight, roading fenders, Product Link, limited slip differential axles (front/rear), power train guard, secondary steering, and sound suppression.

(\$) Specifications and ratings conform to all applicable standards recommended by the Society of Automotive Engineers, including SAE Standard J732C governing loader ratings.

(ISO) Full compliance to ISO 14397-1 (2007) Sections 1 thru 6, which requires 2% verification between calculations and testing.

(Rigid Tire) Compliance to ISO 14397-1 (2007) Sections 1 thru 5.



# Bucket Selection Chart

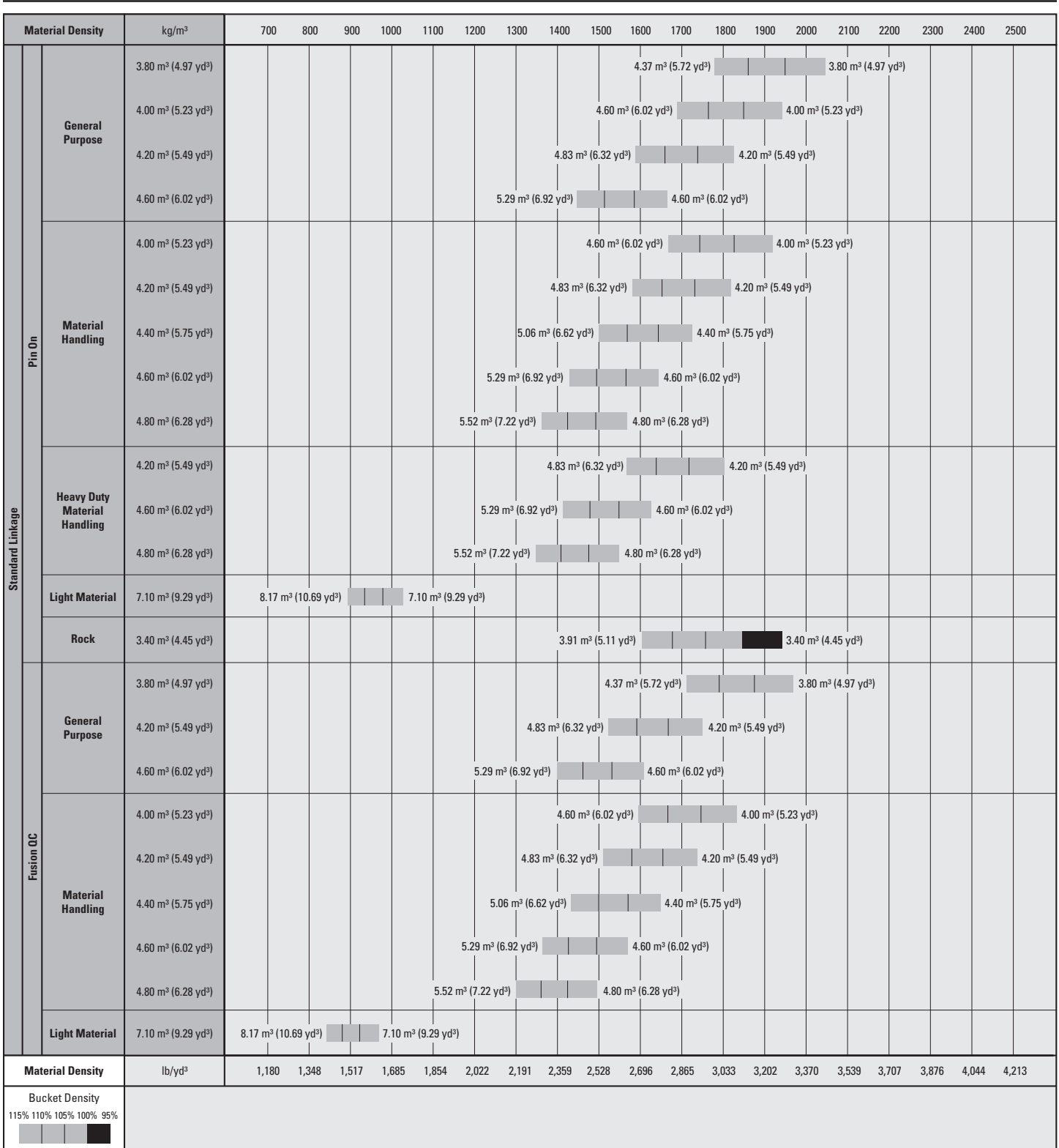

All buckets are showing Bolt-On Edges.  
Material Handling buckets are flat floor buckets.

# 966K Wheel Loader Specifications

## Bucket Selection Chart

Material Density		kg/m <sup>3</sup>	700	800	900	1000	1100	1200	1300	1400	1500	1600	1700	1800	1900	2000	2100	2200	2300	2400	2500			
High Lift Linkage	Pin On	General Purpose	3.80 m <sup>3</sup> (4.97 yd <sup>3</sup> )											4.37 m <sup>3</sup> (5.72 yd <sup>3</sup> )								3.80 m <sup>3</sup> (4.97 yd <sup>3</sup> )		
			4.00 m <sup>3</sup> (5.23 yd <sup>3</sup> )												4.60 m <sup>3</sup> (6.02 yd <sup>3</sup> )								4.00 m <sup>3</sup> (5.23 yd <sup>3</sup> )	
			4.20 m <sup>3</sup> (5.49 yd <sup>3</sup> )												4.83 m <sup>3</sup> (6.32 yd <sup>3</sup> )								4.20 m <sup>3</sup> (5.49 yd <sup>3</sup> )	
			4.60 m <sup>3</sup> (6.02 yd <sup>3</sup> )										5.29 m <sup>3</sup> (6.92 yd <sup>3</sup> )										4.60 m <sup>3</sup> (6.02 yd <sup>3</sup> )	
	Material Handling	4.00 m <sup>3</sup> (5.23 yd <sup>3</sup> )													4.60 m <sup>3</sup> (6.02 yd <sup>3</sup> )								4.00 m <sup>3</sup> (5.23 yd <sup>3</sup> )	
		4.20 m <sup>3</sup> (5.49 yd <sup>3</sup> )													4.83 m <sup>3</sup> (6.32 yd <sup>3</sup> )								4.20 m <sup>3</sup> (5.49 yd <sup>3</sup> )	
		4.40 m <sup>3</sup> (5.75 yd <sup>3</sup> )												5.06 m <sup>3</sup> (6.62 yd <sup>3</sup> )								4.40 m <sup>3</sup> (5.75 yd <sup>3</sup> )		
		4.60 m <sup>3</sup> (6.02 yd <sup>3</sup> )												5.29 m <sup>3</sup> (6.92 yd <sup>3</sup> )								4.60 m <sup>3</sup> (6.02 yd <sup>3</sup> )		
	Heavy Duty Material Handling	4.80 m <sup>3</sup> (6.28 yd <sup>3</sup> )													5.52 m <sup>3</sup> (7.22 yd <sup>3</sup> )								4.80 m <sup>3</sup> (6.28 yd <sup>3</sup> )	
		4.20 m <sup>3</sup> (5.49 yd <sup>3</sup> )													4.83 m <sup>3</sup> (6.32 yd <sup>3</sup> )								4.20 m <sup>3</sup> (5.49 yd <sup>3</sup> )	
		4.60 m <sup>3</sup> (6.02 yd <sup>3</sup> )													5.29 m <sup>3</sup> (6.92 yd <sup>3</sup> )								4.60 m <sup>3</sup> (6.02 yd <sup>3</sup> )	
		4.80 m <sup>3</sup> (6.28 yd <sup>3</sup> )													5.52 m <sup>3</sup> (7.22 yd <sup>3</sup> )								4.80 m <sup>3</sup> (6.28 yd <sup>3</sup> )	
Light Material	7.10 m <sup>3</sup> (9.29 yd <sup>3</sup> )													8.17 m <sup>3</sup> (10.69 yd <sup>3</sup> )								7.10 m <sup>3</sup> (9.29 yd <sup>3</sup> )		
	3.40 m <sup>3</sup> (4.45 yd <sup>3</sup> )													3.91 m <sup>3</sup> (5.11 yd <sup>3</sup> )								3.40 m <sup>3</sup> (4.45 yd <sup>3</sup> )		
Fusion OC	General Purpose	3.80 m <sup>3</sup> (4.97 yd <sup>3</sup> )																					3.80 m <sup>3</sup> (4.97 yd <sup>3</sup> )	
		4.20 m <sup>3</sup> (5.49 yd <sup>3</sup> )													4.83 m <sup>3</sup> (6.32 yd <sup>3</sup> )							4.20 m <sup>3</sup> (5.49 yd <sup>3</sup> )		
		4.60 m <sup>3</sup> (6.02 yd <sup>3</sup> )													5.29 m <sup>3</sup> (6.92 yd <sup>3</sup> )							4.60 m <sup>3</sup> (6.02 yd <sup>3</sup> )		
	Material Handling	4.00 m <sup>3</sup> (5.23 yd <sup>3</sup> )																						4.00 m <sup>3</sup> (5.23 yd <sup>3</sup> )
		4.20 m <sup>3</sup> (5.49 yd <sup>3</sup> )													4.83 m <sup>3</sup> (6.32 yd <sup>3</sup> )								4.20 m <sup>3</sup> (5.49 yd <sup>3</sup> )	
		4.40 m <sup>3</sup> (5.75 yd <sup>3</sup> )													5.06 m <sup>3</sup> (6.62 yd <sup>3</sup> )								4.40 m <sup>3</sup> (5.75 yd <sup>3</sup> )	
		4.60 m <sup>3</sup> (6.02 yd <sup>3</sup> )													5.29 m <sup>3</sup> (6.92 yd <sup>3</sup> )								4.60 m <sup>3</sup> (6.02 yd <sup>3</sup> )	
	Light Material	4.80 m <sup>3</sup> (6.28 yd <sup>3</sup> )													5.52 m <sup>3</sup> (7.22 yd <sup>3</sup> )								4.80 m <sup>3</sup> (6.28 yd <sup>3</sup> )	
		7.10 m <sup>3</sup> (9.29 yd <sup>3</sup> )													8.17 m <sup>3</sup> (10.69 yd <sup>3</sup> )								7.10 m <sup>3</sup> (9.29 yd <sup>3</sup> )	
		3.40 m <sup>3</sup> (4.45 yd <sup>3</sup> )													3.91 m <sup>3</sup> (5.11 yd <sup>3</sup> )								3.40 m <sup>3</sup> (4.45 yd <sup>3</sup> )	
Material Density		lb/yd <sup>3</sup>	1,180	1,348	1,517	1,685	1,854	2,022	2,191	2,359	2,528	2,696	2,865	3,033	3,202	3,370	3,539	3,707	3,876	4,044	4,213			
Bucket Density																								
115% 110% 105% 100% 95%																								

All buckets are showing Bolt-On Edges.  
Material Handling buckets are flat floor buckets.

## Bucket Selection Chart

Material Density		kg/m <sup>3</sup>	700	800	900	1000	1100	1200	1300	1400	1500	1600	1700	1800	1900	2000	2100	2200	2300	2400	2500	
Rounding Pin On	Material Handling	4.20 m <sup>3</sup> (5.49 yd <sup>3</sup> )																				
		4.83 m <sup>3</sup> (6.32 yd <sup>3</sup> )																				
Material Density		lb/yd <sup>3</sup>	1,180	1,348	1,517	1,685	1,854	2,022	2,191	2,359	2,528	2,696	2,865	3,033	3,202	3,370	3,539	3,707	3,876	4,044	4,213	
Bucket Density																						
115% 110% 105% 100% 95%																						

All buckets are showing Bolt-On Edges.  
Material Handling buckets are flat floor buckets.

## Bucket Fill Factors

(as a % of ISO Rated Capacity)

Loose Material	Performance Series Bucket
Earth/Clay	115
Sand and Gravel	115
Aggregate:	
25-76 mm (1 to 3 in)	110
19 mm (0.75 in) and smaller	105
Rock	100

# 966K Standard Equipment

Standard equipment may vary. Consult your Cat dealer for details.

## POWER TRAIN

Brakes, full hydraulic enclosed wet-disc with Integrated Braking System (IBS)  
Brake wear indicators  
Diesel Particulate Filter (DPF)  
Engine, Cat 9.3 that meets Tier 4 Interim/Stage IIIB emission standards  
Fan, radiator, electronically controlled, hydraulically driven, temperature sensing, on demand  
Fuel Management System (FMS)  
Fuel priming pump (electric)  
Fuel/water separator  
Guard, power train  
Guard, vandalism  
Precleaner, engine air intake  
Radiator, unit core (6 fpi) with ATAAC  
Switch, transmission neutralizer lockout  
Torque converter, free wheel stator  
Transmission, automatic planetary power shift (4F/4R)  
Variable Shift Control (VSC)

## ELECTRICAL

Alarm, back-up  
Alternator, 150-amp brushless  
Batteries, (2) maintenance free 1,400 CCA  
Ignition key; start/stop switch  
Lighting system:

- Four halogen work lights
- Two halogen roading lights (with signals)
- Two halogen rear vision lights (hood mounted)

Main disconnect switch  
Receptacle start (cables not included)  
Starter, electric, heavy duty  
Starting and charging system (24-volt)

## OPERATOR ENVIRONMENT

Air conditioner, heater, and defroster (auto temp and fan)  
Beverage holders (2) with storage compartment for cell phone/MP3 player  
Bucket/Work Tool function lockout  
Cab, pressurized and sound suppressed, (ROPS/FOPS) radio ready (entertainment) includes antenna, speakers and converter (12-volt 10-amp)  
Camera, rearview  
Coat hook (2)  
EH controls, lift and tilt function  
EH parking brake  
Computerized monitoring system  
Instrumentation, gauges:

- Digital gear range indicator
- DPF soot loading percent
- Engine coolant temperature
- Fuel level
- Hydraulic oil temperature
- Speedometer/tachometer
- Transmission oil temperature

Instrumentation, warning indicators:

- Axle oil temperature
- Battery voltage hi/low
- Engine air filter restriction
- Engine intake manifold temperature
- Engine oil pressure
- Fuel level and pressure hi/low
- Hydraulic oil filter restriction
- Hydraulic oil low
- Parking brake
- Primary steering oil pressure
- Service brake oil pressure
- Transmission filter bypass

Horn, electric  
Light, two dome (cab)  
Mirrors, rearview external (includes spot mirrors)  
Post mounted membrane switch keypads  
Receptacle, 12-volt  
Seat, Cat Comfort (cloth) air suspension  
Seat belt, retractable, 51 mm (2") wide  
Steering, EH joystick, speed sensing with force feedback  
Sun visor, front  
Wet-arm wipers/washers front and rear

- Intermittent front wiper

Window, sliding (left and right sides)  
Viscous mounts

## TIRES

A tire must be selected from the mandatory attachments section. Base machine price includes an allowance.

## FLUIDS

Premixed 50% concentration of Extended Life Coolant with freeze protection to  $-34^{\circ}\text{C}$  ( $-29^{\circ}\text{F}$ )

## OTHER STANDARD EQUIPMENT

Auto idle shutdown  
Couplings, Cat O-ring face seal  
Ecology drains for engine, transmission, axles, and hydraulics  
Ether aid  
Fenders, steel front with mud-flap/rear with extension  
Filters:

- Fuel, primary/secondary
- Engine air, primary/secondary
- Engine oil
- Hydraulic oil
- Transmission

Fuel cooler  
Grease zerks  
Grill, airborne debris  
Hitch, drawbar with pin  
Hood, non-metallic power tilting with rear clamshell  
Hoses, Cat XT  
Hydraulic oil cooler (swing out)  
Hydraulic system, load sensing  
Kickout, lift and tilt, automatic (adjustable in cab)  
Linkage, Z-bar, cast cross-tube/tilt lever  
Oil sampling valves  
Platform, window washing  
Product Link  
Remote diagnostic pressure taps  
Ride control, 2V  
Service center (electrical and hydraulic)  
Sight gauges: engine coolant, hydraulic oil, and transmission oil level  
Steering, load sensing  
Steering, secondary  
Toolbox  
Vandalism protection caplocks

Optional equipment may vary. Consult your Cat dealer for details.

## Power Train

- Differentials
  - Open, front or rear
  - Limited slip, rear
  - Limited slip, front and rear
- Extreme temperature seals
- Seal guards
- Axle oil cooler

Hydraulics arrangement, 3 valve

Cold start package (240V)

Comfort package

Work lighting package, halogen

Work lighting package, HID

Forestry package

Industrial package

High lift, 2 valve

High lift, 3 valve

Quick coupler

Quick coupler ready, 2V

Quick coupler ready, 3V

Bucket and work tool options  
(contact Cat Work Tools)

Lights, signal LED

Product Link, satellite

Control, aggregate autodig

Joystick, 2 valve

Joystick, 3 valve

Payload control system

Printer, payload CNTL system

Radio, AM/FM CD/MP3 player

Filter, carbon fresh air

Sun visor, rear

Security system, machine

Cooling, high ambient

Guard, front window

Guard, complete cab

Guard, front window (Logger)

Autolube

Fenders, roading with fender extensions  
front/rear

Precleaner, HVAC

Precleaner, turbine

Precleaner, turbine/trash

Oil change system, high speed

Fan, variable pitch

Antifreeze, –50° C (–58° F)

Retractable, 18-degree inclined ladder

Cab filter, carbon fresh air

Cab filter, RESPA

VIMS, satellite 3G

Speed limiter, 20 km/h





# 966K Wheel Loader

For more complete information on Cat products, dealer services, and industry solutions, visit us on the web at [www.cat.com](http://www.cat.com)

© 2011 Caterpillar Inc.  
All rights reserved

Materials and specifications are subject to change without notice. Featured machines in photos may include additional equipment. See your Cat dealer for available options.

CAT, CATERPILLAR, SAFETY.CAT.COM, their respective logos, "Caterpillar Yellow" and the "Power Edge" trade dress, as well as corporate and product identity used herein, are trademarks of Caterpillar and may not be used without permission.

AEHQ6309 (07-2011)  
(Europe and Countries Applying  
EU Emissions Regulations)

